

MOUNTING INSTRUCTION

Light Package / Fan Switch 24 V 20 W
for Extractor Arm Original

No. 148759/00
Date 2005-10-01

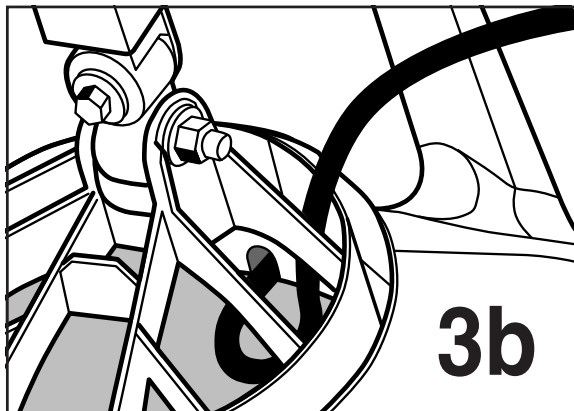
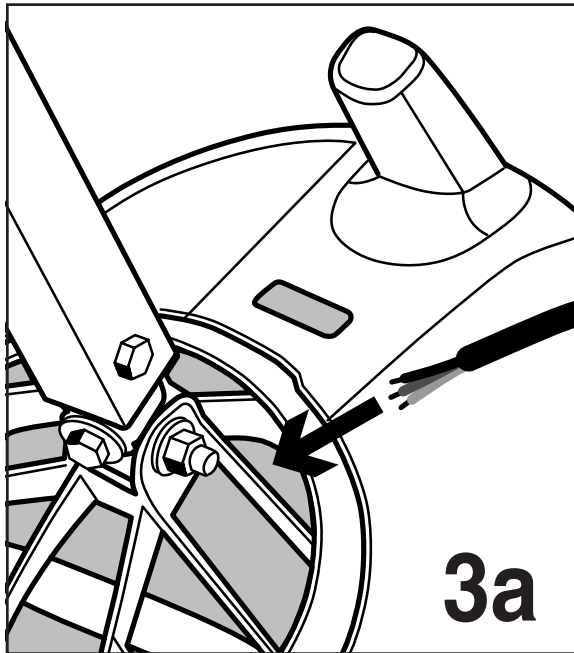
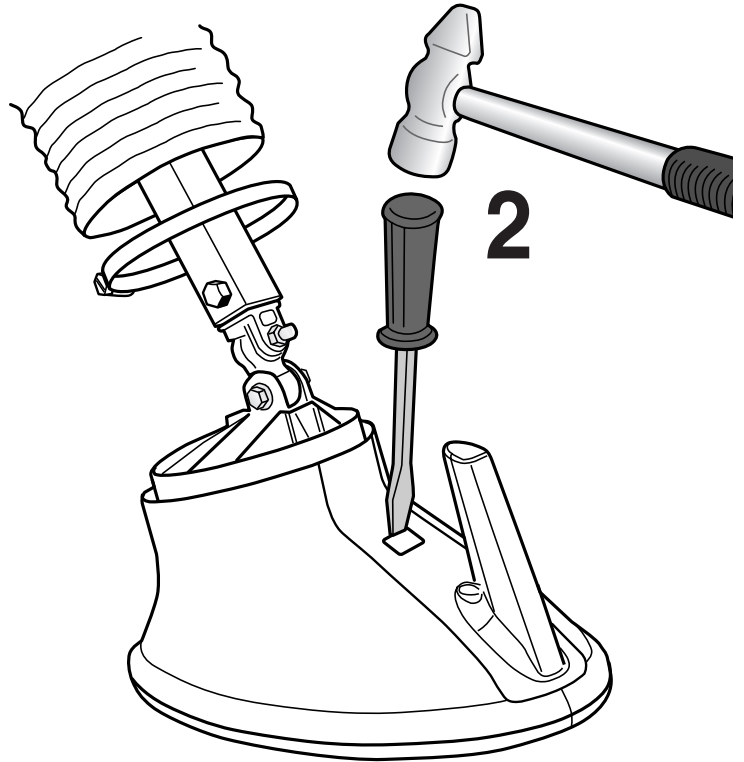
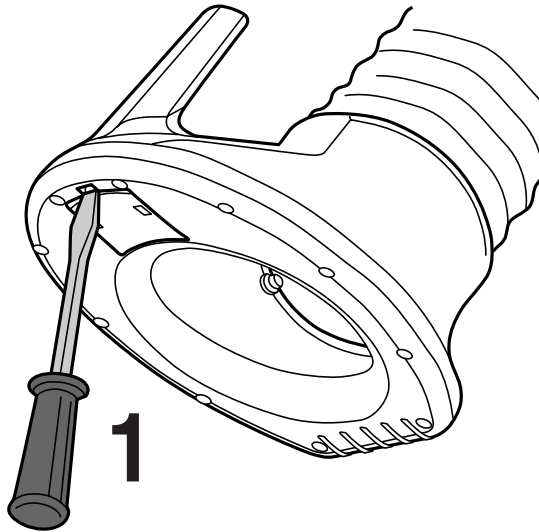

24 V - black / schwarz / noir / negro / nero / zwart / musta / svart
CTRL - brown / braun / marron / marrone / bruin / ruskea / brun
0 V - blue / blau / bleu / azul / blu / blauw / sininen / blå

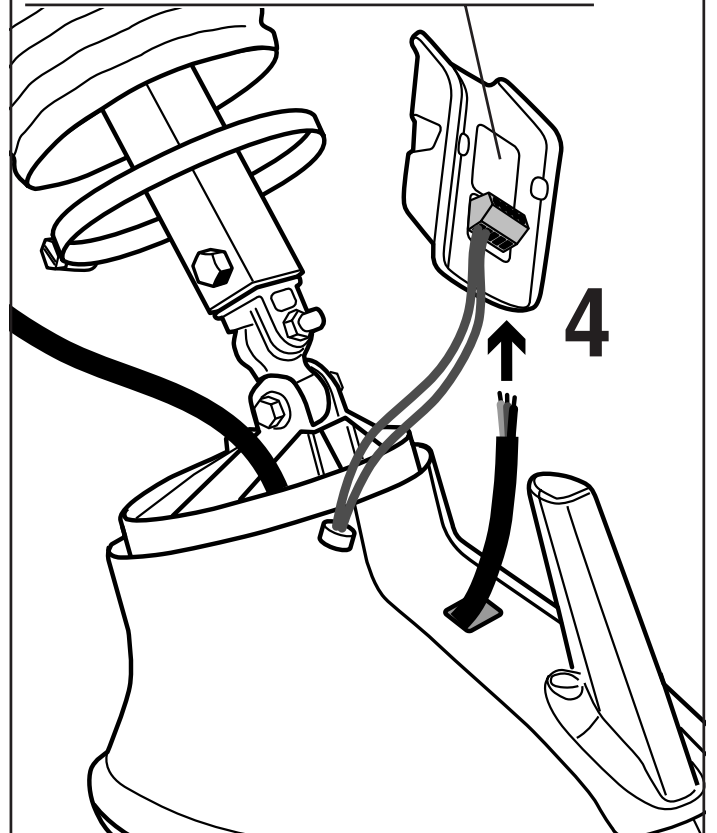

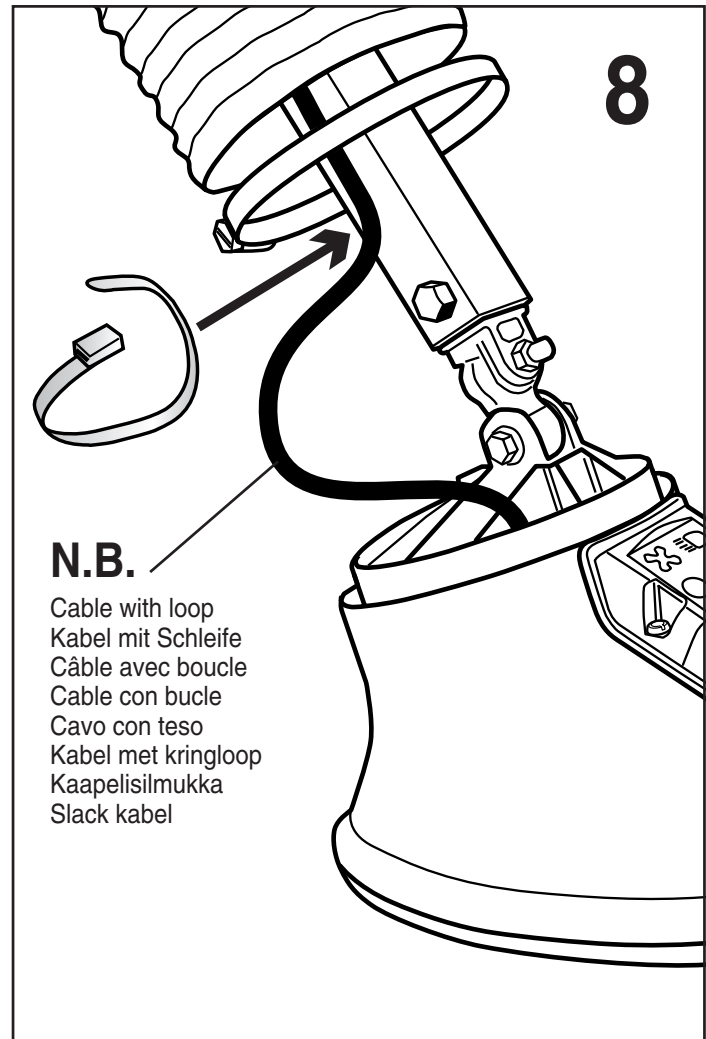
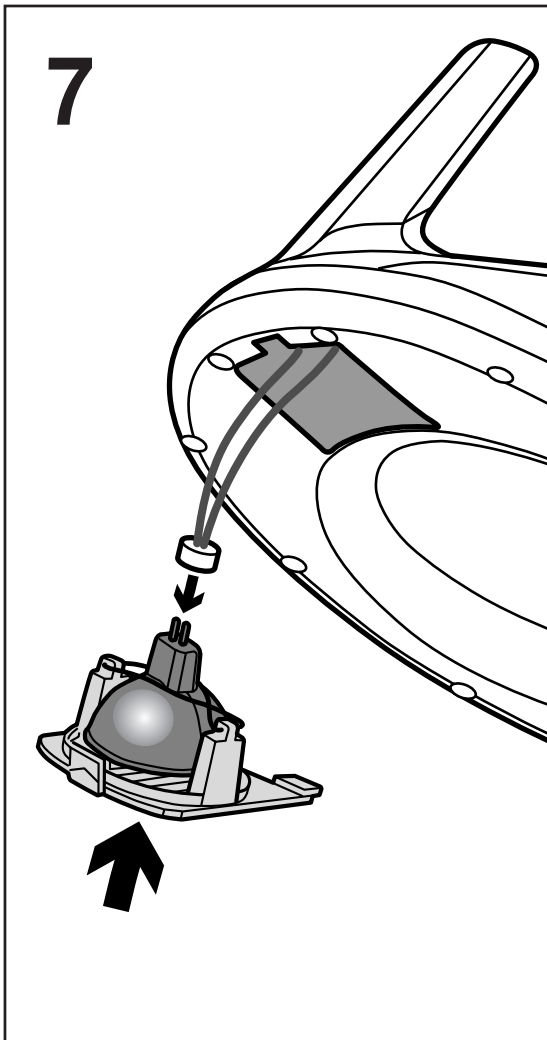
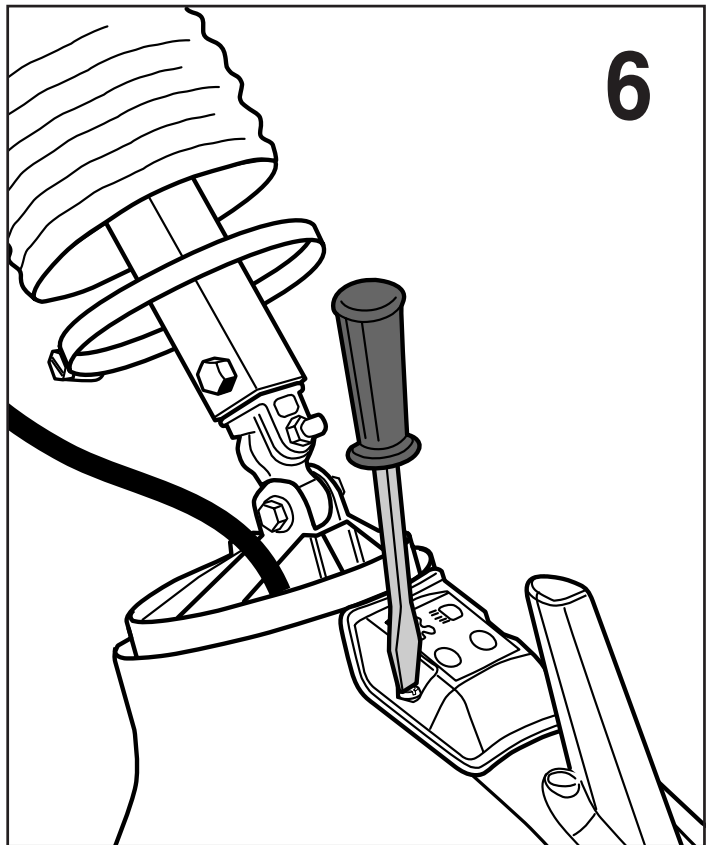
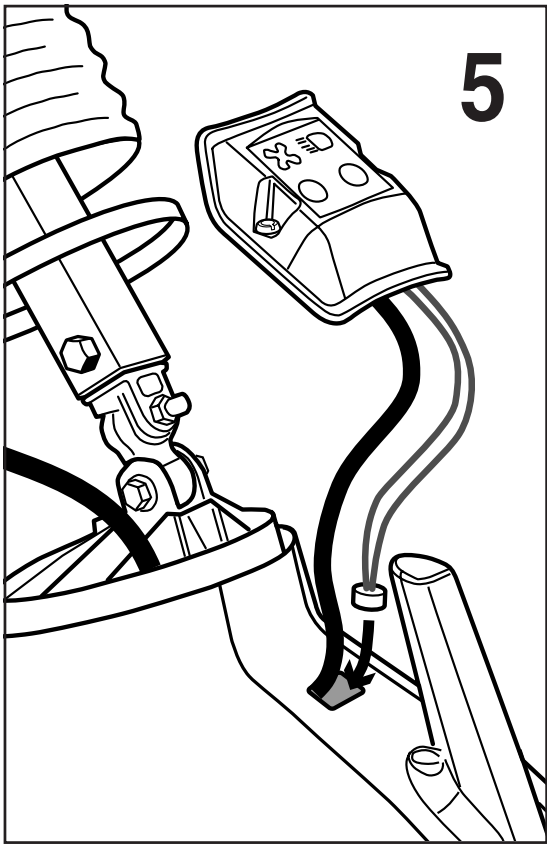

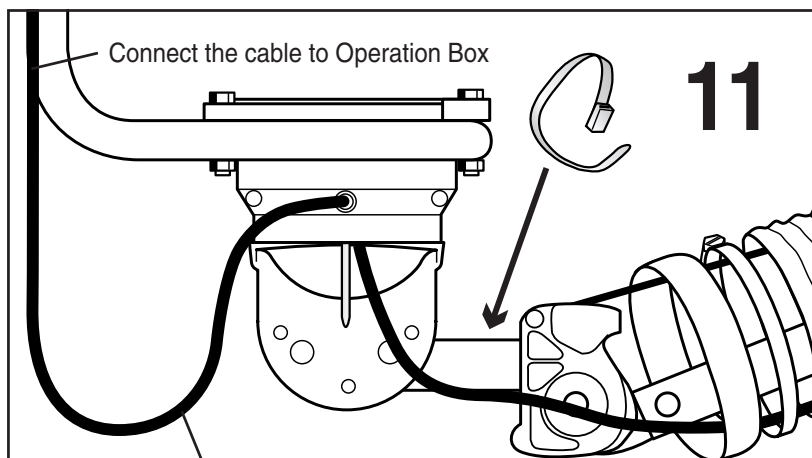
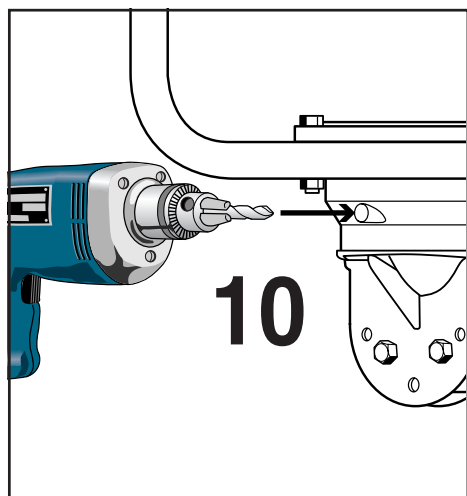
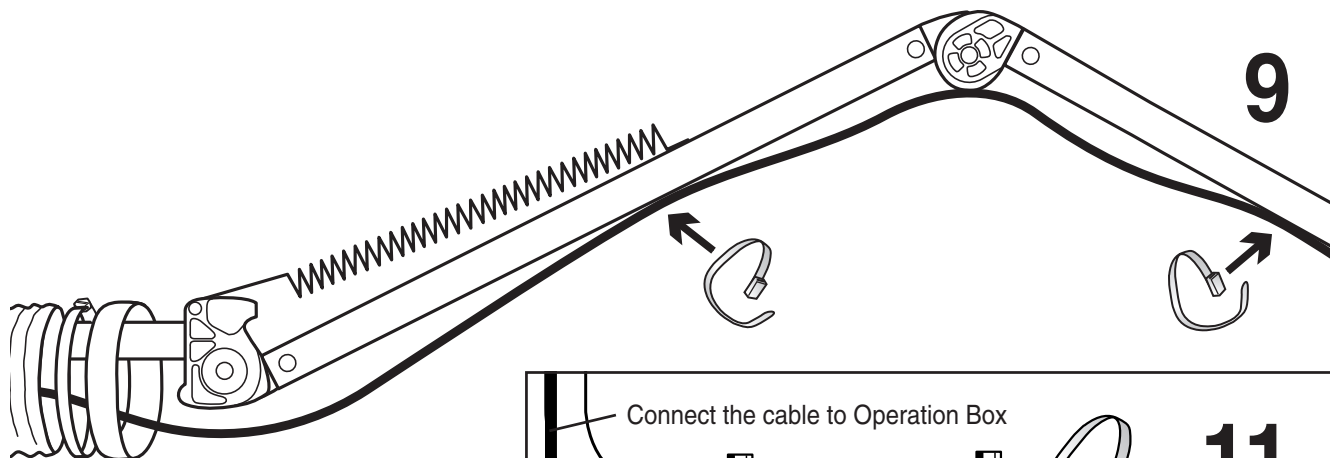

N.B.

Cable with loop	Cavo con tesò
Kabel mit Schleife	Kabel met kringloop
Câble avec boucle	Kaapelisilmukka
Cable con bucle	Slack kabel

GB ENGLISH

Rotation stop (X):
Must be fitted when the arm can be rotated more than 360°.

D DEUTSCH

Drehstop (X):
Muss montiert werden wenn der Arm mehr als 360° geschwenkt werden kann.

FR FRANÇAIS

Butée de rotation (X):
À monter lorsque le bras pourra tourner sur plus de 360°.

ES ESPAÑOL

Tope de rotación (X):
Para instalarse cuando el brazo pueda girar mas de 360°.

IT ITALIANO

Giunto di bloccaggio (X):
Da montare quando il braccio articolato deve essere girato più 360°.

NL NEDERLANDS

Draaistop (X):
Moet gemonteerd worden indien de arm meer dan 360° gedraaid kan worden.

FI SUOMI

Kiertorajoitin (X):
Asetetaan jos letkustoa voidaan kääntää yli 360°.

SE DK NO

Vridstopp (drejestop) (X):
Måste monteras när armen kan vridas (drejes) mer än 360°.

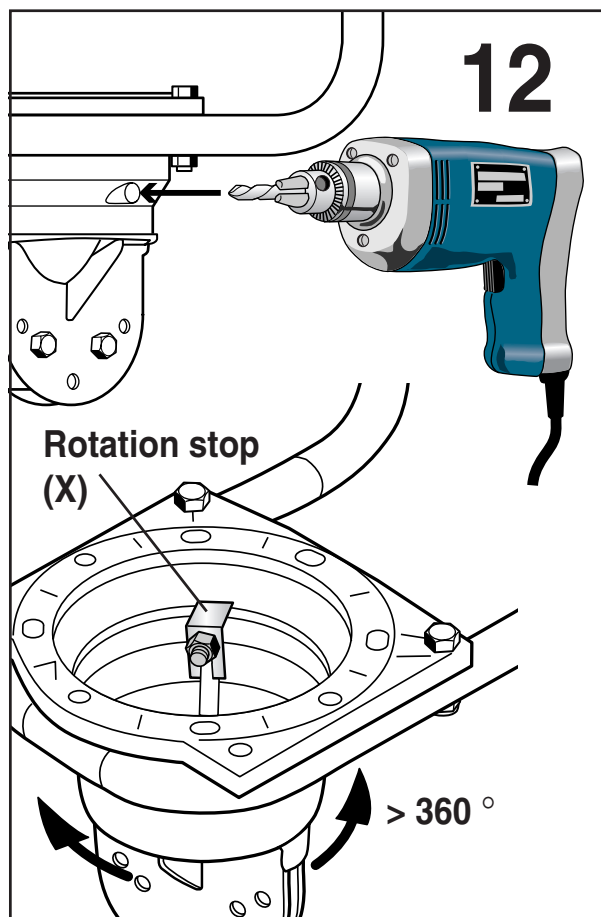

WIRING DIAGRAM

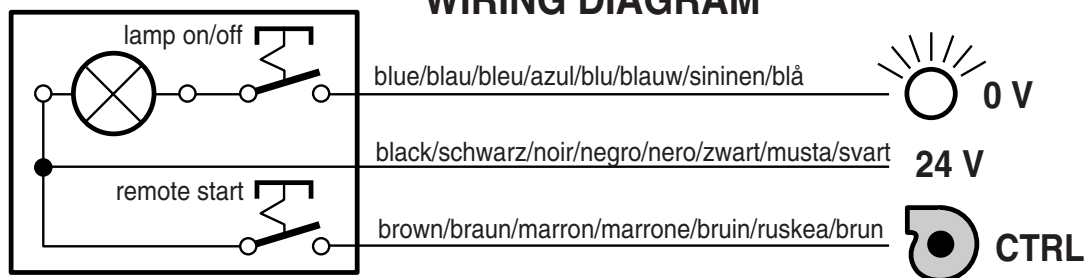

GB ENGLISH

IMPORTANT!

Electric installation should be done by a qualified electrician.

WARNING!



Risk of personal injury.

- Before connecting the Light Package, the power supply must be switched off.
- When working with highly inflammable substances the Light Package must not be installed.

D DEUTSCH

WICHTIG!

Die elektrische Installation darf nur durch einen qualifizierten Elektriker erfolgen.

WARNUNG!



Verletzungsgefahr.

- Schalten Sie die Stromversorgung ab bevor Sie die Arbeitsplatzbeleuchtung einschalten.
- Bei arbeiten mit leicht entflammaren Substanzen darf keine Arbeitsplatzbeleuchtung installiert sein.

FR FRANÇAIS

IMPORTANT!

L'installation électrique doit être effectuée par un électricien qualifié.

ATTENTION!



Risque de blessure.

- Avant d'effectuer la connexion, n'oubliez pas de couper le courant d'alimentation.
- Si des substances inflammables doivent être aspirées, la hotte avec éclairage ne doit être ni proposée, ni installée.

ES ESPAÑOL

¡IMPORTANTE!

La instalación eléctrica debe realizarla un electricista cualificado.

¡ATENCIÓN!



Riesgo de daños personales.

- Desconectar la corriente antes de acoplar el conjunto de iluminación.
- Cuando trabaje con sustancias altamente inflamables no se debe instalar el conjunto de iluminación.

IT ITALIANO

IMPORTANTE!

Il collegamenti elettrici devono essere effettuati da un elettricista qualificato.

ATTENZIONE!



Pericolo di lesioni personali.

- Prima di collegare il set illuminante, interrompere la corrente.
- Quando si lavora con sostanze altamente infiammabili il set illuminante non deve essere installato.

NL NEDERLANDS

BELANGRIJK!

Elektrische installatie mag uitsluitend worden verricht door een erkend elektromonteur.

WAARSCHUWING!



Gevaar voor lichamelijke letsel.

- Alvorens de verlichting te sluiten dient de stroomvoorziening uitgeschakeld te worden.
- Wanneer er gewerkt wordt met sterk ontvlambare stoffen, dient de verlichting niet te worden geïnstalleerd.

FI SUOMI

TÄRKEÄ!

Järjestelmän sähköasennukset tulee antaa pätevä sähköasentajan tehtäväksi.

VAROITUS!



Loukkaantumisvaara.

- Ennen kytkemistä sähköön täytyy olla kytketty pois.
- Kohdevaloa ei saa asentaa letkustoon helposti syttyvien aineiden parissa työskenneltäessä.

SE DK NO

VIKTIG!

Elektrisk installation ska utföras av behörig elektriker.

VARNING!



Risk för personskador.

- Koppla ifrån strömförsörjningen innan belysningen kopplas in.
- Vid utsugning av ångor, gaser o. dyl. som kan medföra explosionsrisk får belysningen inte vara monterad.

Spare Part:

Lamp (x2), Protection glass (x5), Clamp (x2)

Parti di ricambio:

Lampada (x2), Vetro (x5), Briglia (x2)

Ersatzteil:

Lampe (x2), Glas (x5), Bügel (x2)

Reserveonderdel:

Lamp (x2), Lasruit (x5), Veer (x2)

Pièce de rechange:

Lampe (x2), Verre (x5), Crampon (x2)

Varaosat:

Polttimo (x2), Suojalasi (x5), Sanka (x2)

Pieza de repuesto:

Lampara (x2), Cristal (x5), Grampa (x2)

Reservdel:

Lamp (x2), Skyddsglas (x5), Bygel (x2)

Rights reserved for modification of design and measurements. The majority of the products are manufactured within ISO 9001 and ISO 14001-certified Quality- and Environmental system. For more detailed information please contact the manufacturer.