

## Technical Description FAN N24, 60 HZ, 1~

### TECHNICAL DATA

Article no:	14510222
Capacity:	Up to 1500 m <sup>3</sup> /h
Motor power:	0.75 kW
Speed:	3330 rpm
Voltage:	110-120/220-240 V
Phase:	1~
Frequency:	60 Hz
Current at market voltage:	11.4/5.7 A
Degree of protection:	IP 55
Weight:	17 kg

Nederman N24 is a centrifugal fan designed for use with NEDERMAN extraction products. The fan can also be mounted on a stand which is available as an accessory.



- Working temperature: max. 60 °C
- Ambient temperature: -30°C to +40°C
- Impeller with radial tip blades
- Material:
  - Fan casings: galvanised sheet steel
  - Impeller: die cast aluminium
- Surface treatment: epoxypolyester powder paint
- The fan is manufactured in accordance with the following standards or other normative documents: 98/37/EC, 2006/95/EC and 2004/108/EC.

### DIMENSIONS

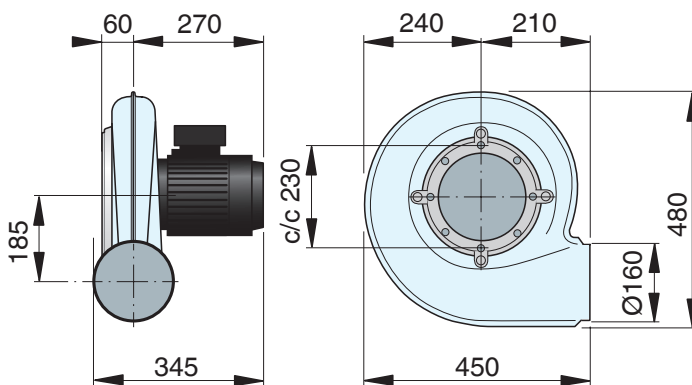

### WARNING!

**Risk of fire or explosion!** The fan must not be used in an environment with danger of explosion or for transport of inflammable or explosive gases.

The graphs are according to ducts connected to the inlet and exhaust side of the fan. Air density = 1,2 kg/m<sup>3</sup>

### FAN DIAGRAM

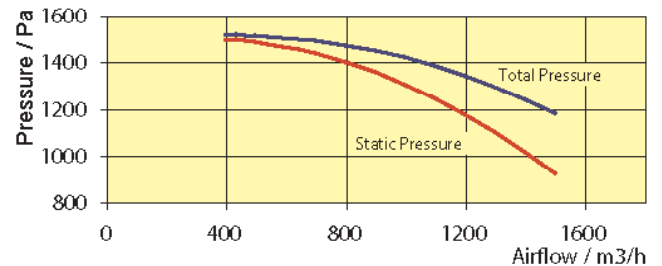

### POWER

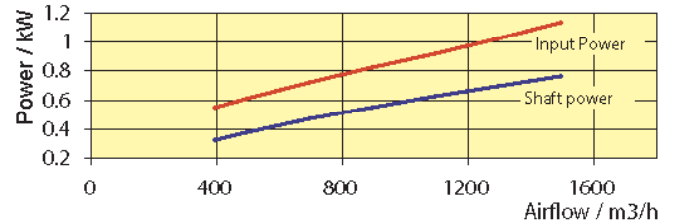

### EFFICIENCY

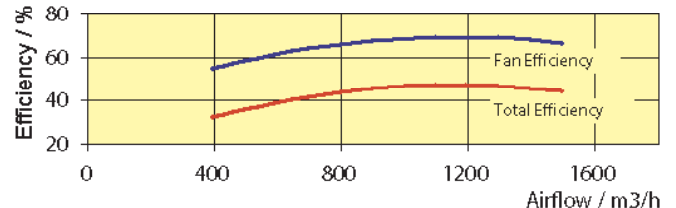

The efficiency concerns the fan without a motor.

### SOUND PRESSURE LEVEL

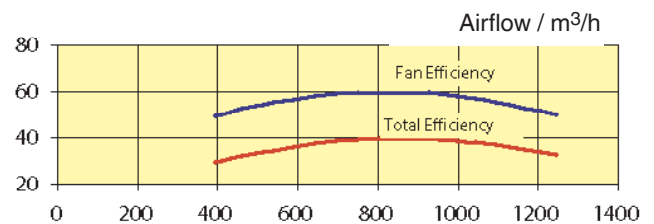

According to ISO 11203.  
Tolerance ± 3 dB.

### SOUND POWER LEVEL

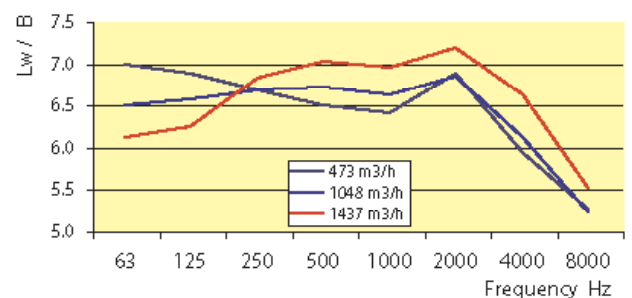

According to ISO 374.  
Tolerance ± 3 dB.