

Vacuum Hose Reel Series 881



The vacuum hose reel facilitates the handling of long and heavy vacuum hoses, and provides tidy and safe storage when they are not in use. Keeps hoses out of the way of forklifts and mobile workshop equipment. Separate suspension brackets make installation of the reel simple and safe.

All reels are delivered without connection hose.

- Antistatic reel and vacuum hose
- Supplied with automatic damper
- Integrated micro-switch

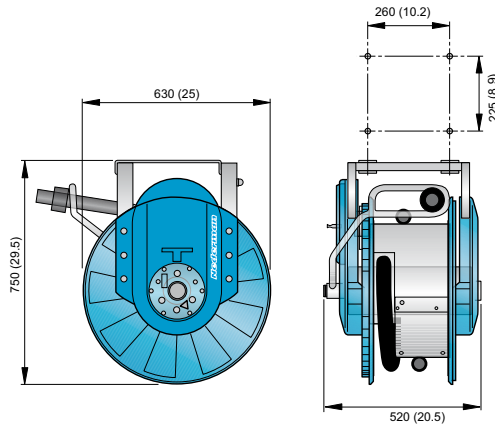

Max. suction, kPa (psi)	Hose dimensions		Hose type (see end of chapter)	Weight, kg (lbs.)	Reel with hose Part no.	Reel without hose Part no.
	Int. Ø, mm (in)	Length, m (ft.)				
45 (7)	38 (1 1/2)	10 (33)	L	26-28 (57-62)	30805081	30804981
	50 (2)	10 (33)	L	26-28 (57-62)	30804881	

Material recycling: 100 %

N.B. All reels are delivered without connection hose.

Pipe system Ø, mm (in.)	Part no.
63 (2 1/2)	30374390
100 (4)	30374389

Installation kits

The kits include all necessary installation material for pipe connections Ø 63 mm (2½ in) or Ø 100 mm (4 in) (branch coupler, joint sleeves, connecting hose P63, brackets 300 mm (12 in), pilot cable, connection box, straps, hose clamps).