

# FilterCart Mobile Extraction/Filter Units

## FilterCart Original

FilterCart Original mobile filter unit for light welding and extraction applications. FilterCart Original includes Extraction Arm Original with an integrated spotlight, which optimizes the user-friendly design. If a larger working range is needed, the 3 m (10 ft.) long arm is recommended.

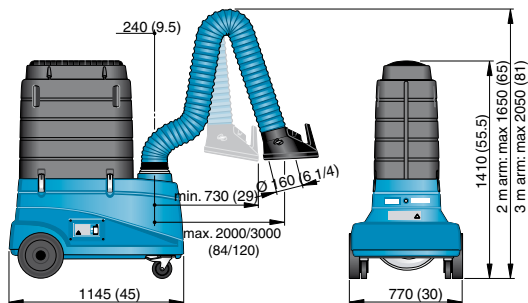

mm (inch)  
Horizontally swivelling arm

Arm length, m (ft.)	Arm Ø, mm (in.)	Max. airflow, m <sup>3</sup> /h (cfm)	Filter efficiency, %	Filter area, m <sup>2</sup> (sq. ft.)	Voltage, V	Power, kW (Hp)	Frequency, Hz	Phase	Noise level, dB(A)	Weight, kg (lb.)	Part no.
2 (7)	160 (6 1/4)	1050 (625)	99	35 (377)	120	0.75 (1)	60	1	73	73 (150)	12624245
3 (10)	160 (6 1/4)	1050 (625)	99	35 (377)	120	0.75 (1)	60	1	73	73 (150)	12624345

Accessories	Part no.
HEPA filter H13, 7.5 m <sup>2</sup> (80 sq. ft.) high efficiency final filter, class H13.	12374016
Spark protection, for mounting in the hood. To reduce risk of fire.	10551335

Replacement filter	Part no.
35 m <sup>2</sup> (344 sq. ft.) flame retardant pleated cellulose material. ≥ 99% efficiency for welding fume. Measured according to the test procedures in EN 15012-1.	12374023



Product availability may differ by country

## FilterCart W3



FilterCart W3 mobile filter unit for extraction in light production applications is “state of the art” with all possible features. Includes a warning signal when the filter is full. The W3 model fulfills the legislations W3 from BGIA. The specially designed metal hood with integrated spotlight creates maximum air velocity at the welding spot.

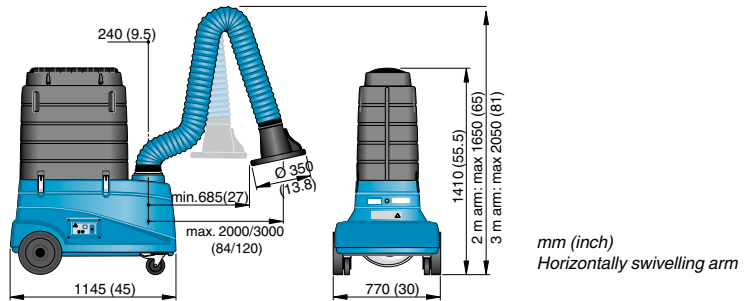

Arm length, m (ft.)	Arm Ø, mm (in.)	Max. airflow, m³/h (cfm)	Filter efficiency, %	Filter area, m² (sq. ft.)	Voltage, V	Power, kW (Hp)	Frequency, Hz	Phase	Noise level, dB(A)	Weight, kg (lb.)	Part no.
3 (10)	160 (6 1/4)	1050 (625)	99	35 (377)	120	0.75 (1)	60	1	73	73 (150)	12634345

Accessories	Part no.
HEPA filter H13, 7.5 m² (80 sq. ft.) high efficiency final filter, class H13.	12374016
Spark protection, for mounting in the hood. To reduce risk of fire.	10551335

Replacement filter	Part no.
35 m² (380 sq. ft.) flame retardant pleated cellulose material. ≥ 99% efficiency for welding fume. Measured according to the test procedures in EN 15012-1.	12374023

## FilterCart Carbon



FilterCart Carbon mobile filter unit is specially designed for extraction of odours. FilterCart Carbon includes Extraction Arm Standard and can be equipped with HEPA filter for maximum efficiency. Applications: solvents, fumes and other gas contaminants.

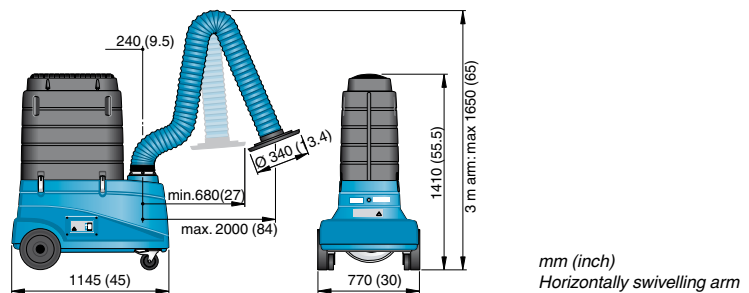

Arm length, m (ft.)	Arm Ø, mm (in.)	Max. airflow, m³/h (cfm)	Filter efficiency, %	Filter	Voltage, V	Power, kW (Hp)	Frequency, Hz	Phase	Noise level, dB(A)	Weight, kg (lb.)	Part no.
2 (7)	160 (6 1/4)	600 (350)	99	20 kg (44 lb.) activated carbon	120	0.55 (0.75)	60	1	74	82 (194)	12644245

Accessory	Part no.
HEPA filter H13, 7.5 m² (80 sq. ft.) high efficiency final filter, class H13.	12374016

Replacement filter	Part no.
20kg (44 lb.) activated antracite carbon for general use.	12374025

Product availability may differ by country